

96500334 CR 20-10 50 Hz

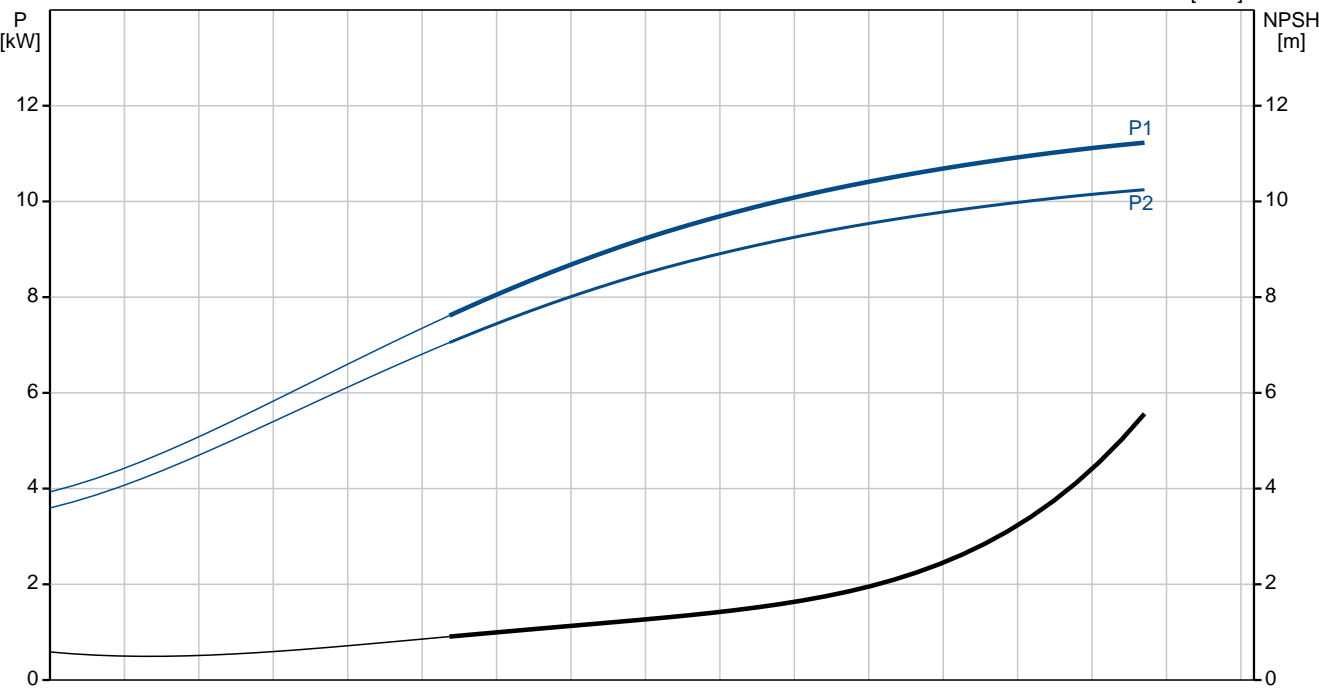

Description	Value
Product name:	CR 20-10 A-F-A-E-HQQE
Product No:	96500334
EAN number:	5700396199641
Price:	On request
Technical:	
Speed for pump data:	2924 rpm
Rated flow:	21 m ³ /h
Rated head:	118 m
Head max:	148 m
Impellers:	10
Shaft seal:	HQQE
Approvals on nameplate:	CE, TR
Curve tolerance:	ISO 9906:1999 Annex A
Pump type:	CR 20
Stages:	10
Pump version:	A
Model:	A
Materials:	
Pump housing:	Cast iron EN-JL1030 ASTM A48-30 B
Impeller:	Stainless steel DIN W.-Nr. 1.4301 AISI 304
Material code:	A
Code for rubber:	E
Installation:	
Maximum ambient temperature:	60 °C
Max pressure at stated temp:	16 bar / 120 °C 16 bar / -20 °C
Flange standard:	DIN
Connect code:	F
Pipe connection:	DN 50
Pressure stage:	PN 16
Flange size for motor:	FF300
Liquid:	
Pumped liquid:	Water
Liquid temperature range:	-20 .. 120 °C
Liquid temp:	20 °C
Density:	998.2 kg/m ³
Kinematic viscosity:	1 mm ² /s
Electrical data:	
Motor type:	160MB
IE Efficiency class:	IE3
Number of poles:	2
Rated power - P2:	11 kW
Power (P2) required by pump:	11 kW 11 kW
Mains frequency:	50 Hz
Rated voltage:	3 x 220-240 D/380-415 Y V
Rated current:	36,0-34,5/20,8-19,8 A
Starting current:	660-780 %
Cos phi - power factor:	0,88-0,84
Rated speed:	2940-2950 rpm
Efficiency:	IE3 91,2%
Motor efficiency at full load:	91,2-91,2 %
Motor efficiency at 3/4 load:	91,8-91,8 %
Motor efficiency at 1/2 load:	91,3-91,2 %
Enclosure class (IEC 34-5):	55 (Protect. water jets/dust)
Insulation class (IEC 85):	F
Motor protec:	PTC
Motor No:	85U07524
Others:	
Label:	Grundfos Blueflux
Minimum efficiency index, MEI :	0.7
Net weight:	149 kg
Gross weight:	177 kg

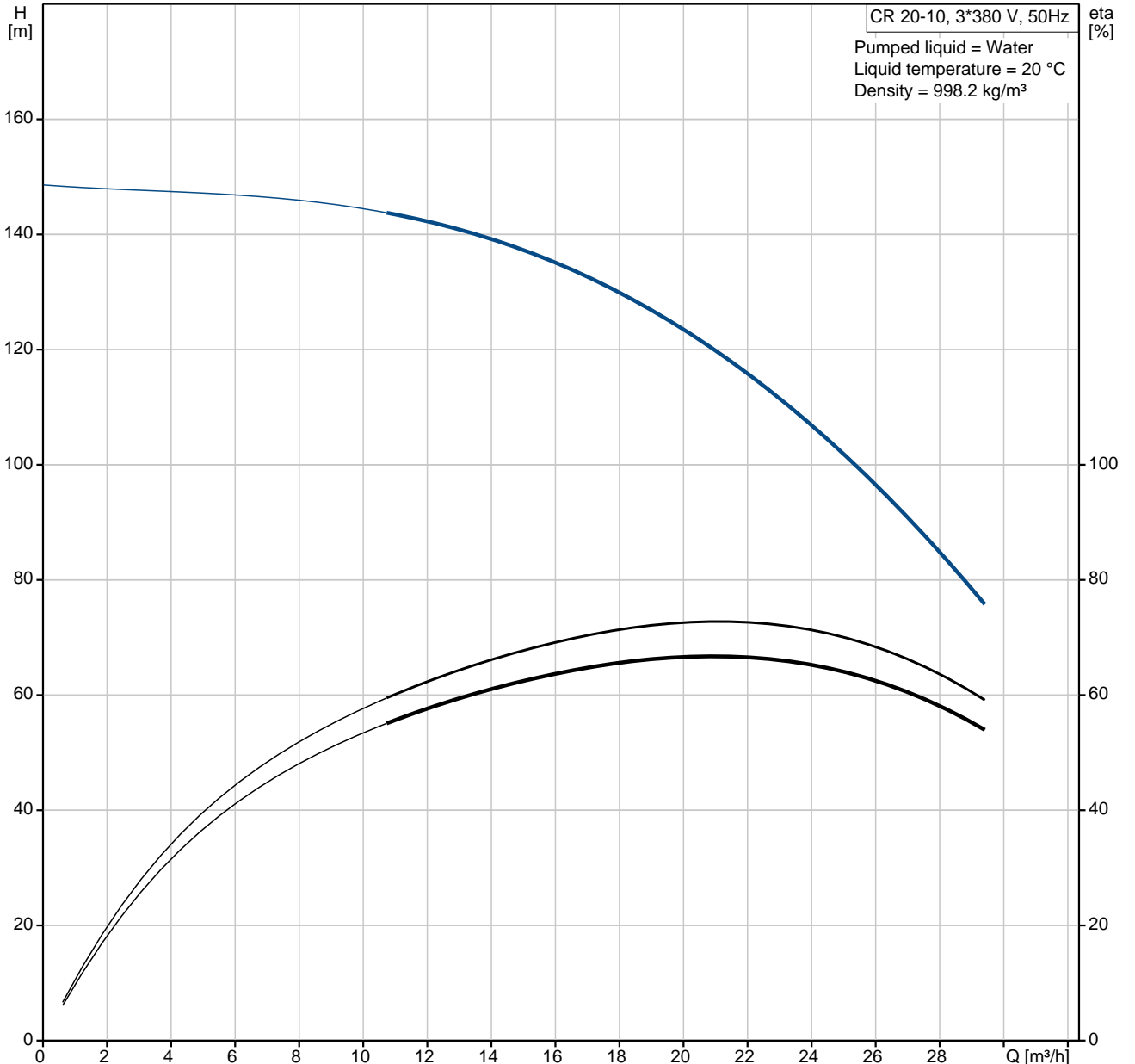
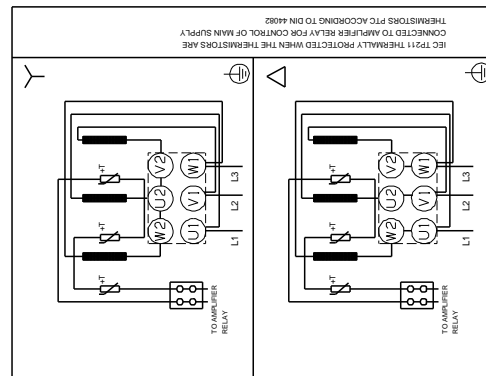
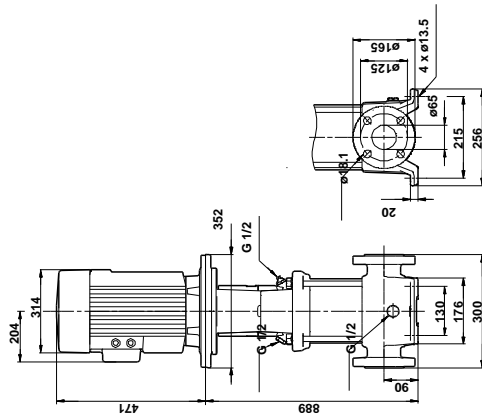
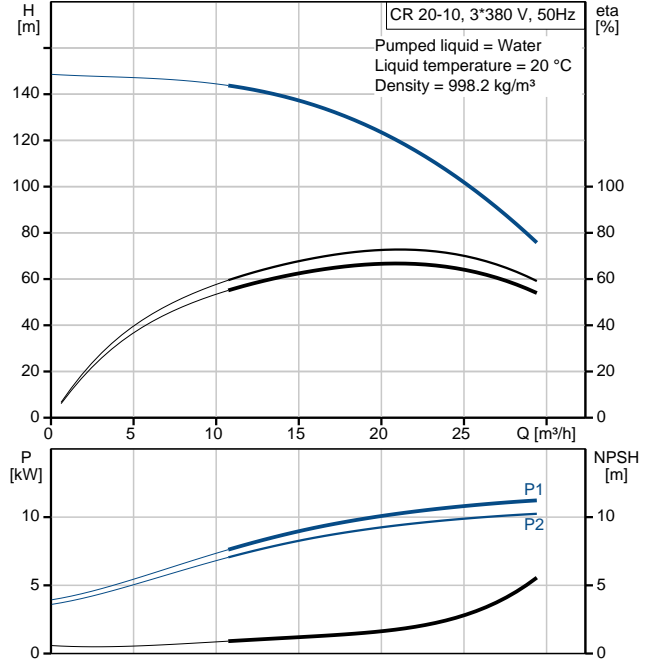

Description	Value
Shipping volume:	0.56 m3

96500334 CR 20-10 50 Hz

CR20-10 + 160MB 11 kW 3*380 V, 50 Hz

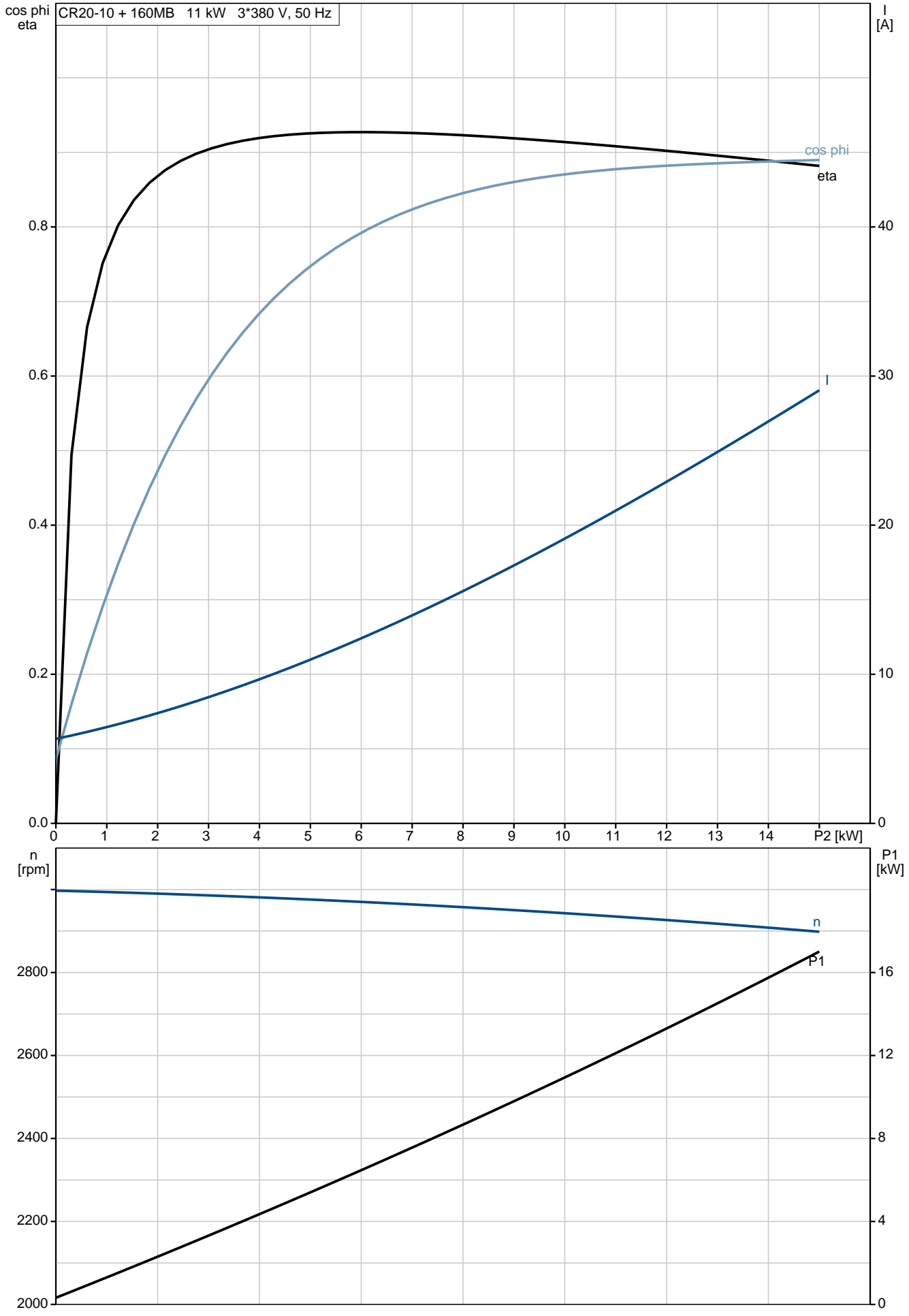

96500334 CR 20-10 50 Hz

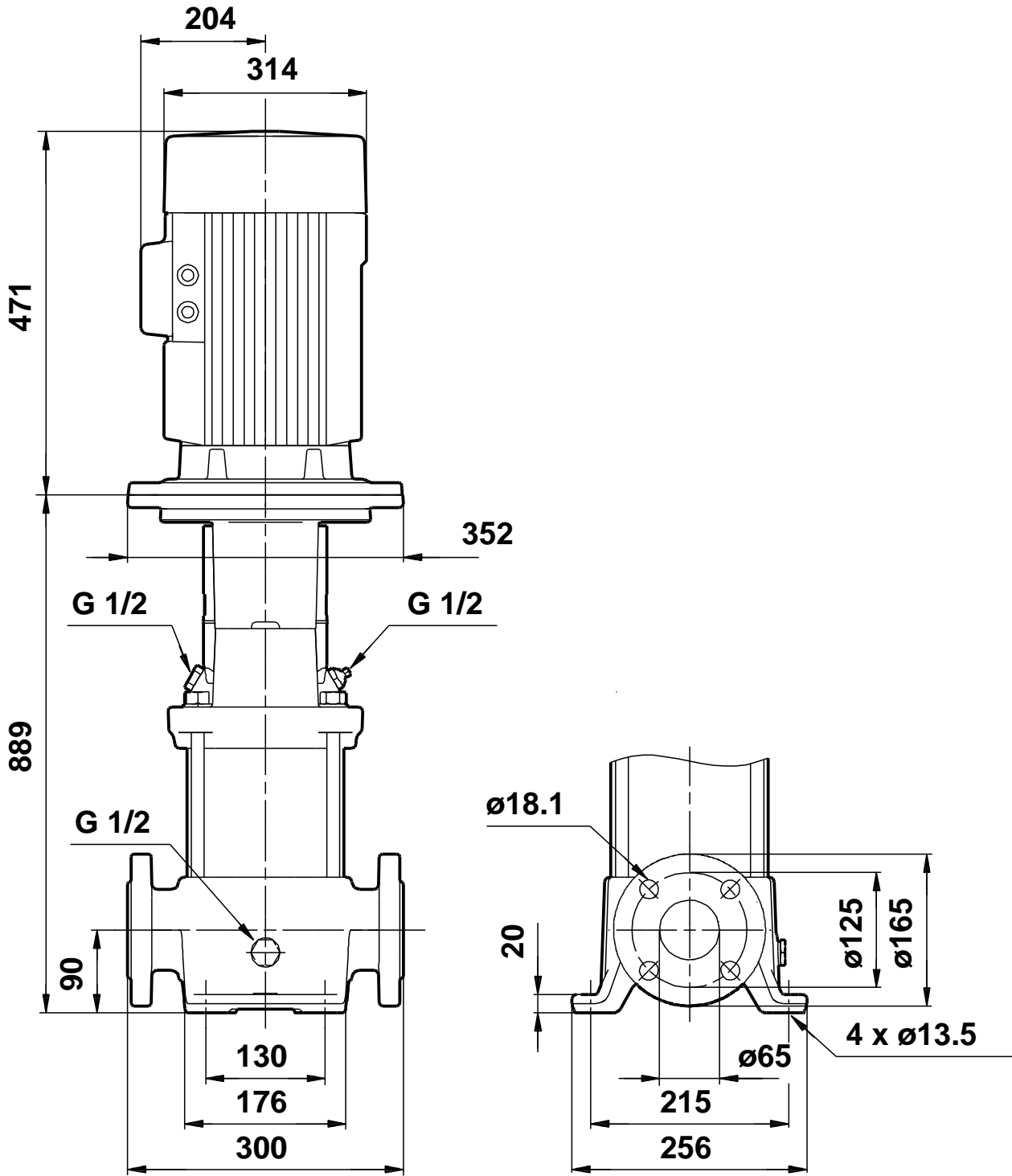

Note! All units are in [mm] unless others are stated.
Disclaimer: This simplified dimensional drawing does not show all details.