

# 96578133 CR 5-22 50 Hz

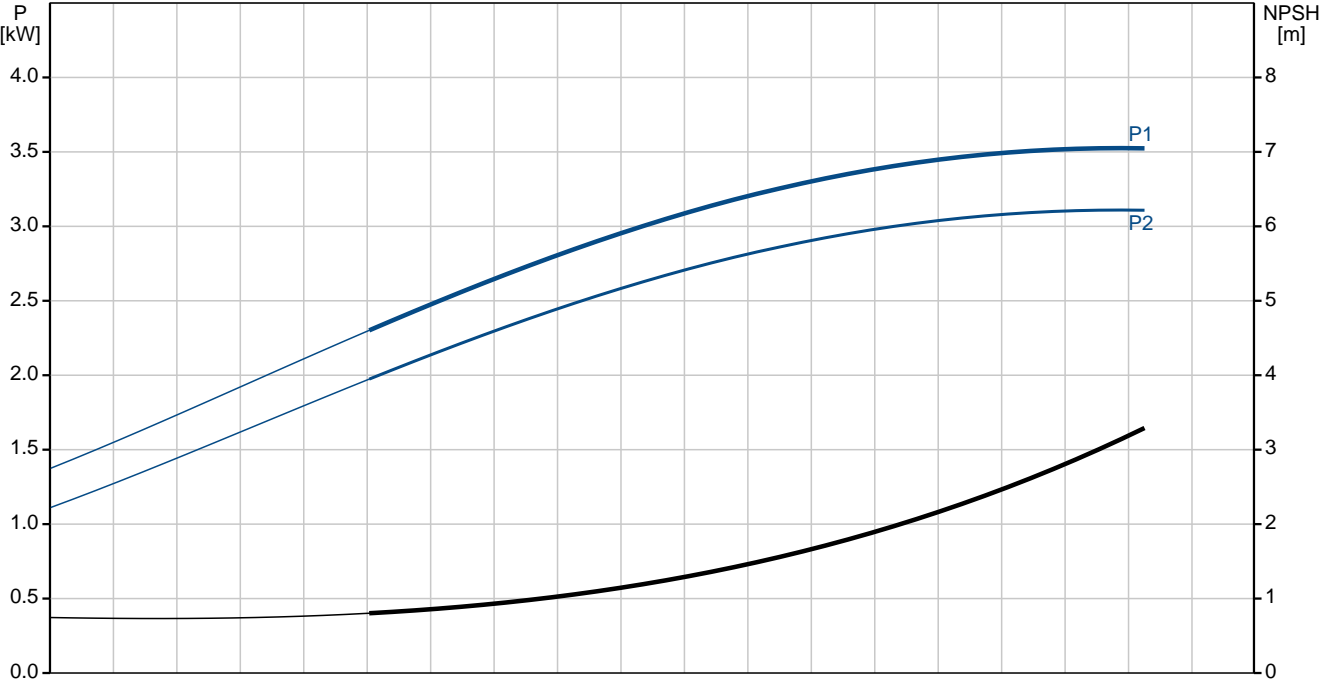

Description	Value
Product name:	CR 5-22 A-A-A-E-HQQE
Product No:	96578133
EAN number:	5700830808726
Price:	On request
<b>Technical:</b>	
Speed for pump data:	2917 rpm
Rated flow:	5.8 m³/h
Rated head:	115 m
Head max:	150 m
Impellers:	22
Shaft seal:	HQQE
Approvals on nameplate:	CE, TR
Curve tolerance:	ISO 9906:1999 Annex A
Pump type:	CR 5
Stages:	22
Pump version:	A
Model:	A
<b>Materials:</b>	
Pump housing:	Cast iron EN-JL1030 ASTM A48-30 B
Impeller:	Stainless steel DIN W.-Nr. 1.4301 AISI 304
Material code:	A
Code for rubber:	E
<b>Installation:</b>	
Maximum ambient temperature:	60 °C
Max pressure at stated temp:	16 bar / 120 °C 16 bar / -20 °C
Flange standard:	OVAL
Connect code:	A
Pipe connection:	Rp 1 1/4
Flange size for motor:	FT130
<b>Liquid:</b>	
Pumped liquid:	Water
Liquid temperature range:	-20 .. 120 °C
Liquid temp:	20 °C
Density:	998.2 kg/m³
Kinematic viscosity:	1 mm²/s
<b>Electrical data:</b>	
Motor type:	112MC
IE Efficiency class:	IE3
Number of poles:	2
Rated power - P2:	4 kW
Power (P2) required by pump:	4 kW
Mains frequency:	50 Hz
Rated voltage:	3 x 380-415 D V
Rated current:	7.9 A
Starting current:	1000-1110 %
Cos phi - power factor:	0,87-0,87
Rated speed:	2920-2940 rpm
Efficiency:	IE3 88,1%
Motor efficiency at full load:	88,1-88,1 %
Motor efficiency at 3/4 load:	88,6-88,2 %
Motor efficiency at 1/2 load:	85,2-88,1 %
Enclosure class (IEC 34-5):	55 (Protect. water jets/dust)
Insulation class (IEC 85):	F
Motor protec:	PTC
Motor No:	85U15413
<b>Others:</b>	
Label:	Grundfos Blueflux
Minimum efficiency index, MEI :	0.57
Net weight:	61.7 kg
Gross weight:	66.3 kg
Shipping volume:	0.11 m3

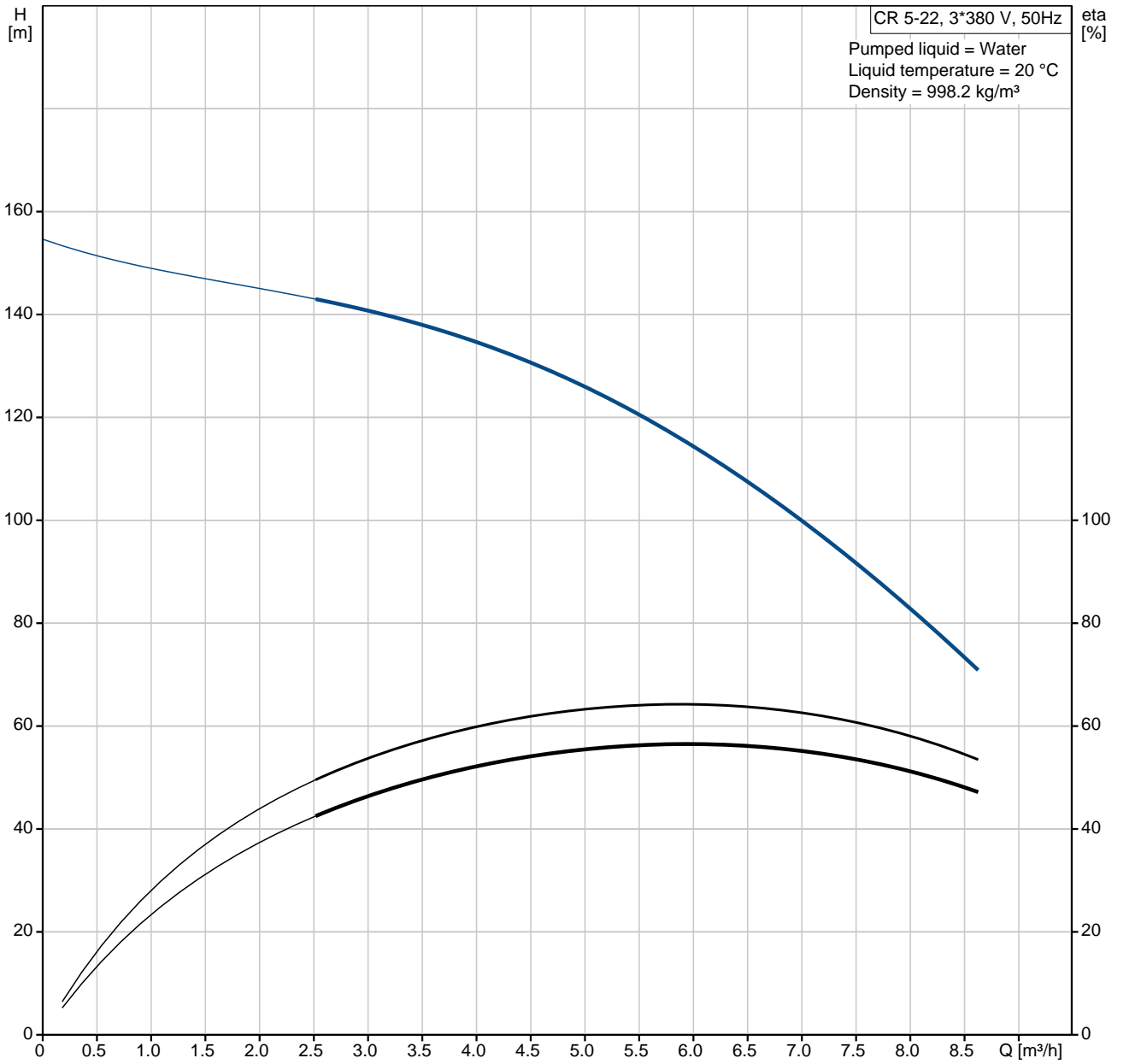
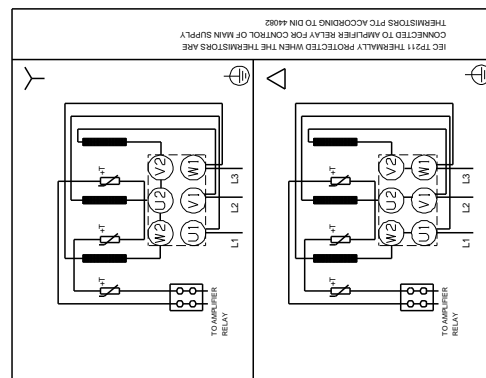
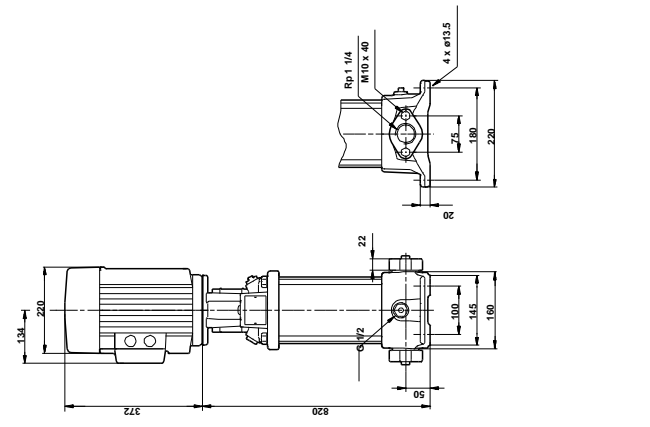
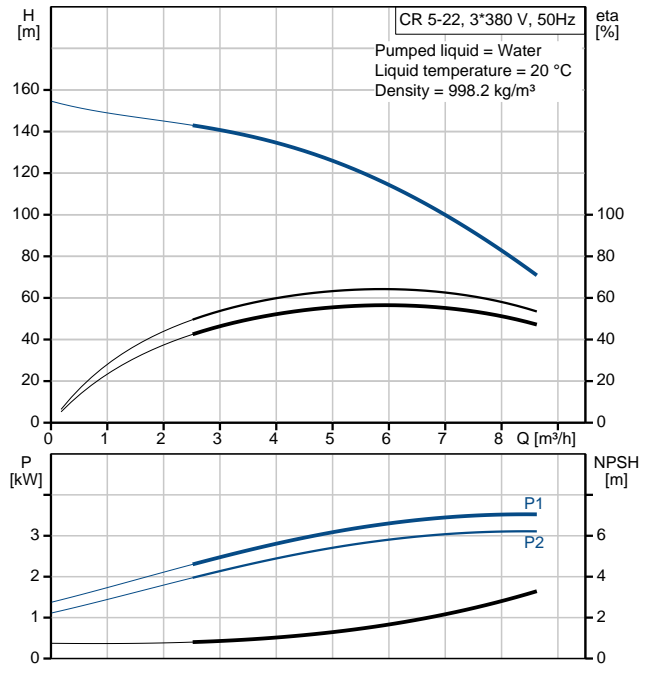

# 96578133 CR 5-22 50 Hz

CR5-22 + 112MC 4 kW 3\*380 V, 50 Hz

