

96086662 TP 32-250/2 50 Hz

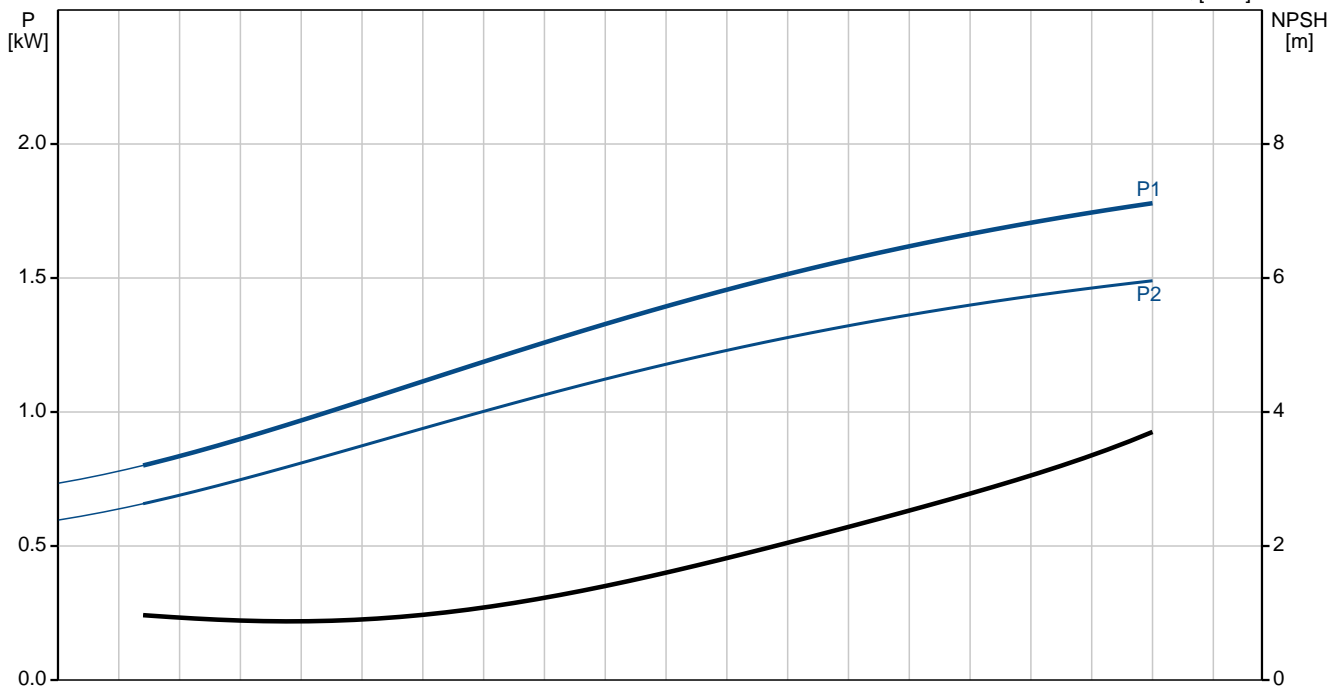

Description	Value
Product name:	TP 32-250/2 A-F-A-BAQE
Product No:	96086662
EAN number:	5700395306088
Price:	On request
Technical:	
Speed for pump data:	2900 rpm
Rated flow:	13.6 m ³ /h
Rated head:	20 m
Head max:	250 dm
Actual impeller diameter:	140 mm
Shaft seal:	BAQE
Curve tolerance:	ISO 9906:1999 Annex A
Pump version:	A
Model:	A
Materials:	
Pump housing:	Cast iron EN-JL1040 ASTM A48-40 B
Impeller:	Cast iron EN-JL1030 ASTM A48-30 B
Material code:	A
Installation:	
Maximum ambient temperature:	60 °C
Maximum operating pressure:	16 bar
Flange standard:	DIN
Connect code:	F
Pipe connection:	DN 32
Pressure stage:	PN 16
Port-to-port length:	340 mm
Flange size for motor:	FF165
Liquid:	
Pumped liquid:	Water
Liquid temperature range:	0 .. 120 °C
Liquid temp:	20 °C
Density:	998.2 kg/m ³
Electrical data:	
Motor type:	90SB
IE Efficiency class:	IE3
Number of poles:	2
Rated power - P2:	1.5 kW
Power (P2) required by pump:	1.5 kW
Mains frequency:	50 Hz
Rated voltage:	3 x 220-240 D/380-415 Y V
Rated current:	5,45/3,15 A
Starting current:	850-930 %
Cos phi - power factor:	0,87-0,82
Rated speed:	2890-2910 rpm
Efficiency:	IE3 84,2%
Motor efficiency at full load:	84,2 %
Motor efficiency at 3/4 load:	84,5-83,9 %
Motor efficiency at 1/2 load:	83,1-81,0 %
Enclosure class (IEC 34-5):	55 (Protect. water jets/dust)
Insulation class (IEC 85):	F
Motor protec:	NONE
Motor No:	87220289
Others:	
Label:	Grundfos Blueflux
Minimum efficiency index, MEI :	0.70
Net weight:	47 kg
Gross weight:	56 kg
Shipping volume:	0.13 m ³

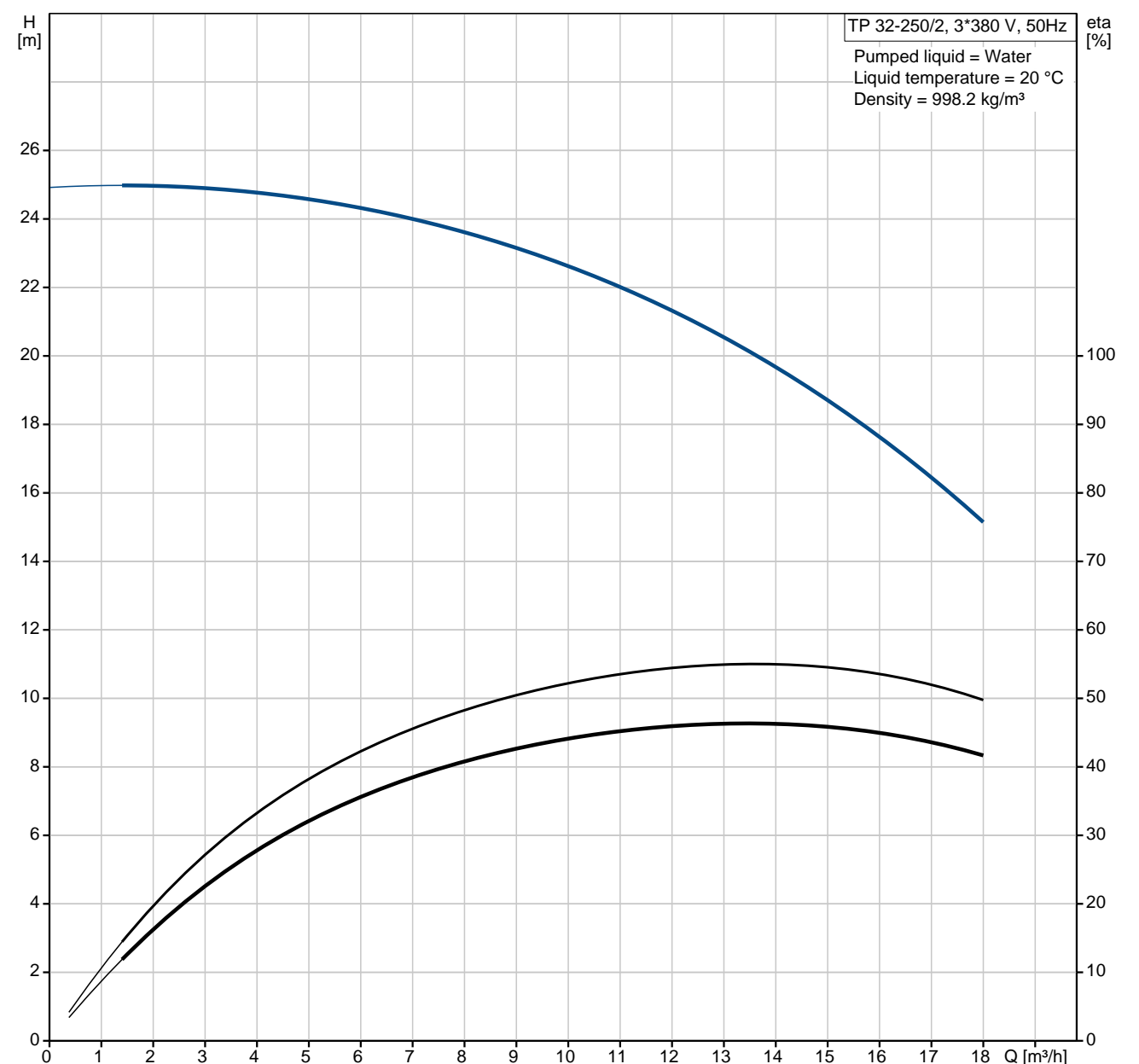
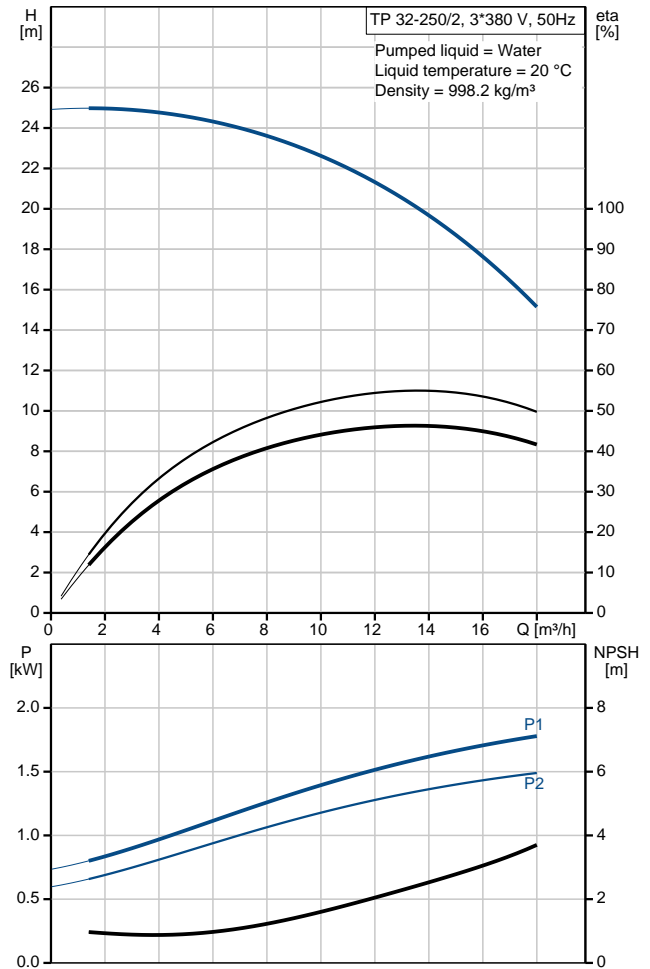

96086662 TP 32-250/2 50 Hz

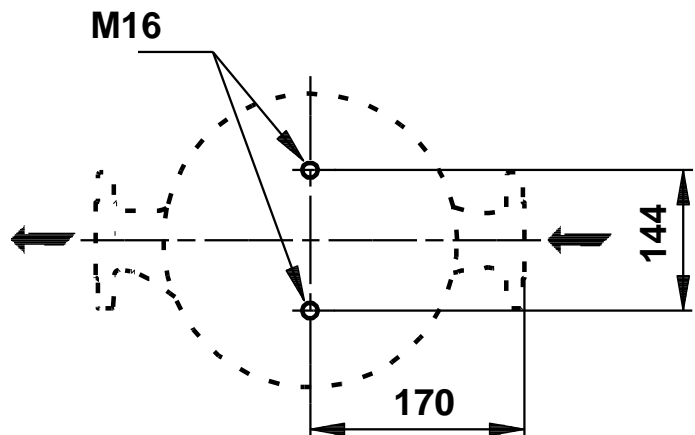
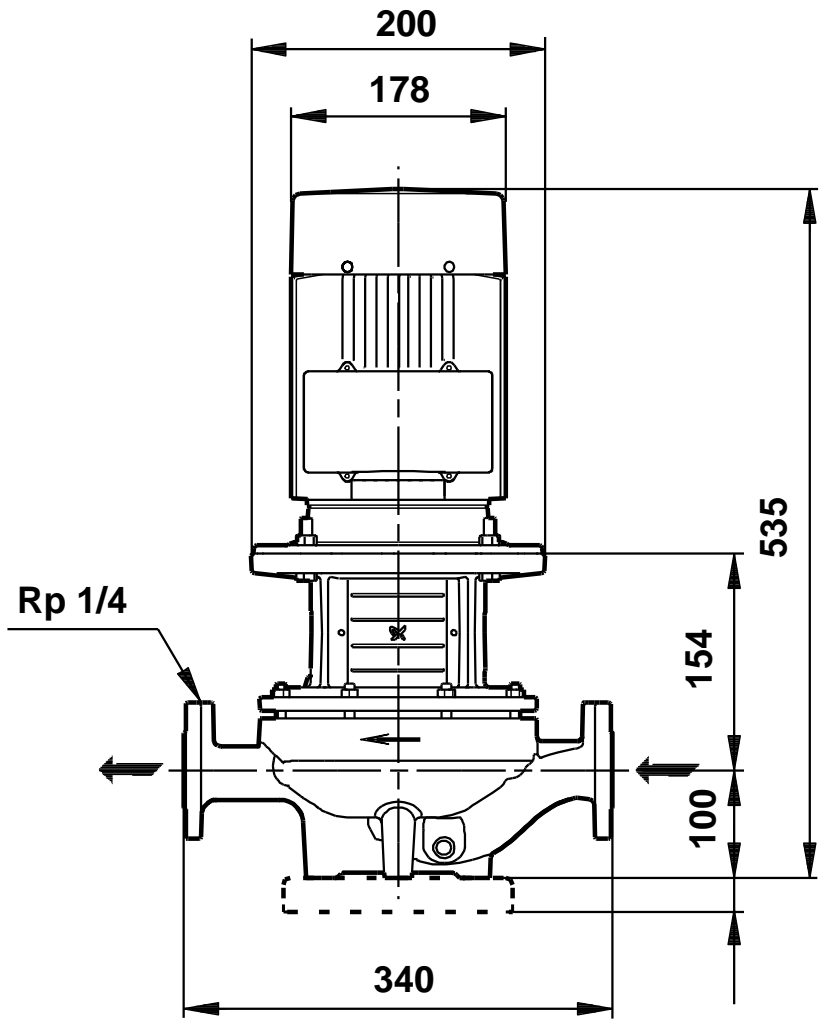
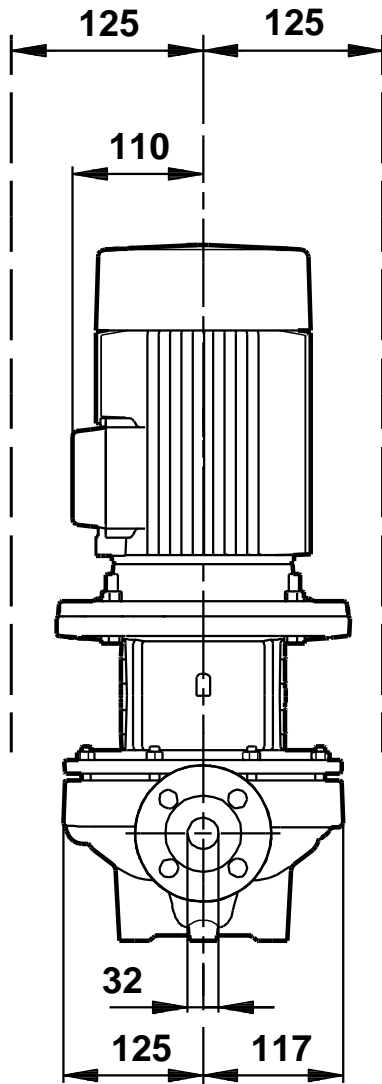

Note! All units are in [mm] unless others are stated.
Disclaimer: This simplified dimensional drawing does not show all details.